

*Please Read These Instructions
Before Using Your Mower*



REVOLUTION 26

OWNER'S MANUAL

REV26-6





Do not operate this machine before it has been assembled correctly and you have read and understood these instructions.



These instructions are intended as a general guide and do not supersede national or local codes in any way. Contact local Authorities for clarity of laws relating to operation of this appliance.

Keep the instructions in a safe place for future use.

Contents

Symbols in this Owner's Manual	2
Symbols used on the machine	2
Proper Use	3
Safety Precautions	3
Safe Practices for Walk Behind Mowers	4
Reel Mower General Arrangement	5
Contents of the Shipping Container	5
Assembly Instructions	6
Before you Start	7
Using your Reel Mower	8
Adjustments for best performance	9
Cutting Reel Cluth Adjustment	11
General Maintenance	12
Cleaning and storage	12
Specifications	12
Troubleshooting	13

Symbols in this Owner's Manual



Threatened hazard or hazardous situation. Not observing this instruction can lead to injuries or cause damage to property.



Important information on proper handling. Not observing this instruction can lead to faults in the machine.



User information. This information helps you to use all the functions correctly.



Always wear ear and eye protection when using the machine.

Symbols used on the Machine



Read and understand this Owner's Manual before operating the machine.



Keep bystanders clear. Danger of flying objects.



Warning! Keep hands and feet clear of rotating reel.



Caution rotating reel - keep hands and feet clear.



Remove Spark Plug.



Noise Limit



Keep hands and feet clear of rotating reel.

Proper Use

For safety reasons, the Reel Mower is not to be used by children, young people, or any other persons who are not acquainted with these directions for use.



Specific safety information. Please read this safety information and the directions for use carefully and be sure to follow the instructions to the letter.



Warning

Even though this machine has been designed to be safe in use, it is essential to follow the Safe Working instructions carefully to avoid accidents to persons or property.

Safety Precautions

UNDERSTAND YOUR REEL MOWER

Read and understand the owner's manual and labels affixed to the Reel Mower. Learn its application and limitations as well as the specific potential hazards peculiar to it.

DRUGS, ALCOHOL AND MEDICATION

Do not operate the Reel Mower while under the influence of drugs, alcohol, or any medication that could affect your ability to use it properly.

1. Your Reel Mower is a piece of power equipment, not a toy, and should be operated with extreme caution at all times.
2. Children should never be allowed to operate the Reel Mower. Only persons acquainted with the rules of safe operation set forth in this manual should be allowed to operate the machine.
3. Read the complete manual to fully understand the function of all the accessories and controls.
4. Keep other people, children and pets well away from the area of operation as there is a risk of objects being thrown out during operation.
5. Do not stand in front of the machine when starting the engine or when the machine is running.
6. Wear hearing and eye protection.
7. Do not operate the machine barefoot or with open sandals. Quality footwear is recommended.
8. Do not wear loose fitting clothing that could become caught in the moving parts of the machine.
9. Do not place feet or hands on or near the reel while the engine is running.
10. Do not attempt to adjust the reel and bed knife when the engine is running.
11. Do not leave the machine unattended when the engine is running.
12. Check the fuel supply before starting the engine. Do not fill the fuel tank with the machine indoors, while the engine is running or while the engine is hot. Replace the fuel cap securely, and wipe off any spilled gasoline before starting the engine.



Warning

Gasoline is extremely flammable; spilled fuel can cause a fire or explosion.

13. Do not run the machine indoors. Engine exhaust gases are deadly poisonous.



14. Do not touch the engine muffler during or after operation of the machine. It is extremely hot and can cause severe burns.



15. Do not change the engine governor speed setting. Over-rewing of engine can damage the machine and endanger the operator.
16. Before doing maintenance on the machine, remove the spark plug wire and ground it to the engine block for added safety.
17. Do not attempt to remove debris from the reel without stopping the engine and removing the spark plug wire for added safety. Make sure the reel has stopped completely before attempting to clear the debris.
18. Keep all bolts and fasteners on the machine tight and check them at regular intervals.
19. Do not leave the machine exposed to the weather. Use the grass catcher to cover the motor— even when stored indoors.
20. Do not store the machine inside a building with gasoline in the tank where fumes can reach an open flame or spark. Allow the engine to cool completely before storing inside any enclosure.

Important!



The engine is shipped WITHOUT FUEL or OIL. After assembly, service engine with gasoline and oil as instructed in the separate engine manual packed with your unit.

Note!



Reference to right or left side of your Reel Mower is viewed from the operating position.

Safe practices for Walk-Behind Mowers

IMPORTANT

This cutting machine is capable of amputating hands and feet and throwing objects. Failure to observe the following safety instructions could result in serious injury or death.

I. GENERAL OPERATION

1. Read, understand, and follow all instructions on the machine and in the manual(s) before starting.
2. Do not put hands or feet near or under the machine. Keep clear of the discharge opening at all times.
3. Only allow responsible adults, who are familiar with the instructions, to operate this machine.
4. Clear the area of objects such as rocks, wire, toys, etc., which could be thrown by the blade. Stay behind the handle when the engine (motor) is running.
5. Be sure the area is clear of bystanders before operating. Stop machine if anyone enters the area.
6. Do not operate machine barefooted or while wearing sandals. Always wear substantial footwear.
7. Do not pull the machine backward unless absolute necessary. Always look down and behind before and while moving backward.
8. Never direct discharge material toward anyone. Avoid discharging material against a wall or obstruction. Material may ricochet back toward the operator. Stop the reel when crossing gravel surfaces.
9. Do not operate machine without the entire grass catcher, discharge guard, rear guard, or other safety protective devices in place and working.
10. Never leave a running machine unattended.
11. Stop the engine (motor) and wait until the reel blades come to a complete stop before clearing the machine, removing grass catcher or unclogging the discharge guard.
12. Operate machine only in daylight or good artificial light.
13. Do not operate machine while under the influence of alcohol or drugs.
14. Never operate mower in wet grass. Always be sure of your footing; walk; never run.
15. Disengage the drive system, if so equipped, before starting the engine.
16. If the machine should start to vibrate abnormally, stop the engine and check for the cause immediately. Vibration is generally a sign of trouble.
17. Always wear eye protection when operating machine.
18. See manufacturer's instructions for proper operation and installation of accessories. Only use accessories approved by the manufacturer.

II. SLOPE OPERATION

Slopes are a major factor related to slip and fall accidents, which can result in severe injury. Operation on all slopes requires extra caution. If you feel uneasy on a slope, do not mow it.

1. Mow across the face of slopes; never up and down. Exercise extreme caution when changing direction on slopes.
2. Watch for holes, ruts, bumps, rocks or other hidden objects. Uneven terrain could cause a slip and fall accident.
3. Do not mow near drop-offs, ditches, or embankments. You could lose your footing or balance.

III. CHILDREN

Tragic accidents can occur if the operator is not alert to the presence of children. Children are often attracted to the machine and the mowing activity. Never assume that children will remain where you last saw them.

1. Keep children out of the mowing area and under the watchful care of a responsible adult other than the operator.
2. Be alert and turn mower off if a child enters the area.
3. Never allow children to operate the machine.
4. Use extra care when approaching blind corners, shrubs, trees, or other objects that may block your view of a child.

IV. SERVICE

* SAFE HANDLING OF GASOLINE:

To avoid personal injury or property damage, use extreme care in handling gasoline. Gasoline is extremely flammable and the vapours are explosive.

1. Extinguish all cigarettes, cigars, pipes, and other sources if ignition.
2. Use only an approved gasoline container.
3. Never remove gas cap or add fuel with the engine running. Allow engine to cool before refuelling.
4. Never refuel the machine indoors.
5. Never store the machine of fuel container where there is an open flame, spark, or pilot light such as on a water heater or on other appliances.
6. Never fill containers inside a vehicle or on a truck or trailer and refuel it on the ground. If this is not possible, then refuel such equipment with a portable container, rather than from a gasoline dispenser nozzle.
7. Keep the nozzle in contact with the rim of the fuel tank or container opening at all times until fuelling is complete. Do not use a nozzle lock-open device.
8. If fuel is spilled on clothing, change clothing immediately.
9. Never overfill fuel tank. Replace gas cap and tighten securely.

GENERAL SERVICE

1. *Never operate machine in a closed area.
2. Keep all nuts and bolts tight to be sure the equipment is in safe working condition.
3. Never tamper with safety devices. Check their operation regularly.
4. Keep machine free of grass, leaves, or other debris build-up. *Clean up oil or fuel spillage and remove any fuel-soaked debris. Allow machine to cool before storing.
5. If you strike a foreign object, stop and inspect the machine. Repair, if necessary, before starting.
6. Never make any adjustments or repairs with the engine (motor) running. *Disconnect the spark plug wire and ground against engine to prevent unintended starting.
7. Always unplug electric mowers before adjusting, cleaning, or repairing.
8. Check grass catcher components and the discharge guard frequently and replace with manufacturer's recommended parts, when necessary.
9. The mower reel blades and bed knife are sharp. Wrap the reel or wear gloves, and use extra caution when servicing them.
10. * Do not change engine governor setting or overspeed the engine.
11. Maintain or replace safety instruction labels, as necessary.

** Asterisked items do not apply to electric mowers.*

Reel Mower General Arrangement



Contents of the Carton

In the carton you will find...

- One reel mower — assembled.
- One grass catcher.
- Upper and lower handle assembly.
- Owner's Manual— this publication.
- Engine Owner's Manual.
- The Express Warranty card.
- 4 Plastic cable ties.
- 6mm nuts and bolts for clutch cable adjusters.

Assembly Instructions

LOWER HANDLE.

To facilitate shipping the handle is not attached to the mower. It has two parts, an upper and a lower one. Fit the lower handle (the one without a hand grip) first. It does not matter which way around it is fitted. Bolt it loosely to the lugs at the rear of the mower using the four bolts provided. Note that the lower bolts pass through slots to provide adjustment for the handle height. After fitting the upper handle, adjust it to the desired height and tighten all four bolts firmly

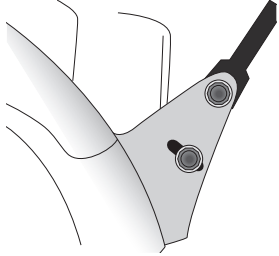

UPPER HANDLE.

Keeping the upturned handle grip on top, fit the lower ends of the top handle over the bottom handle and align the holes for the cam locks.

Remove the nut and washer from the Folding Handlebar levers bolt but leave the rectangular wear plate in position as you pass the bolt through the holes from the outside. The flattened part of the bolt fits the slot in the upper handle. While the lever will work with the bolt fitted either way in the slot, we suggest fitting the bolt so that the lever will point to the top of the handle when locked. Fit the washer and nut on the inside of the bolt and adjust the nut to give the desired clamping action. Fit the second cam lock in the same way.

USING THE 'FOLDING HANDLEBAR' LEVERS.

Swing the upper handle to the operating position and lock it in place by pushing the Lever(s) upwards towards the upper handle. The firmness of the locking action can be adjusted by turning the nut on the inside of the lever bolt.

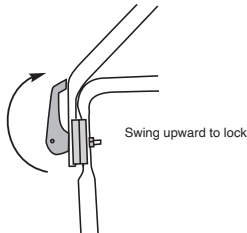

THE LEVERS ON SOME MOWERS ARE REVERSED FOR SHIPPING.

To turn them around unwind the nut to the end of the thread with a 13mm socket, pull the lever outwards and rotate in 180. Retighten the nut until the handle locks firmly in place and it does not change position when in use.

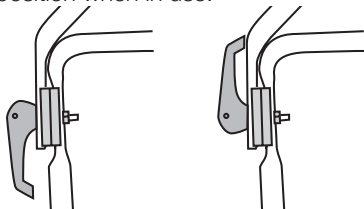

ATTACHING THE CABLES

All models have three cables that need to be attached:

1. The engine throttle control cable.
2. The roller clutch cable.
3. The Reel clutch cable

1. THE ENGINE THROTTLE CONTROL CABLE.

The control lever housing must be fitted to the outside of the upper handle. The cable will have a retainer that fits under the left-hand cam lock levers nut & washer. Loosen the nut and screw and fit it to the outside left-hand side of the handle and tighten the nut & screw. When doing this, ensure the control cable runs above the lower handle cross bar to avoid damaging the cable when the handle is folded for storage.

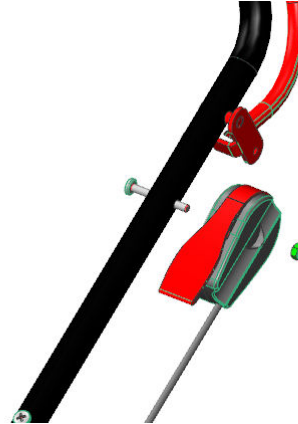

2. FITTING THE GROUND SPEED CATCH CABLE.

The cable will be already attached to the mower at the lower end. The clutch cable is the one that enters the mower under the shaft cover the other end has a 'z' bend fitting. With the cable running above the cross bar of the lower handle, feed the end of the 'z' fitting through the small hole in the roller clutch bail, found below the handle. Turn the 'z' fitting so the cable is running alongside the upper handle.

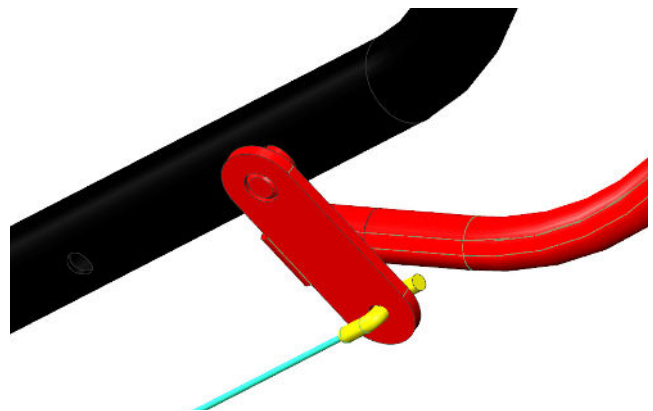

Fit the cable anchor up under the handle tube and attach it to the tube with the fastener provided.

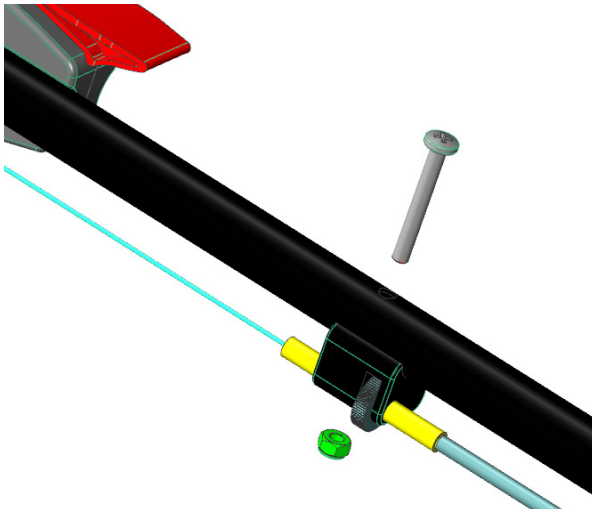

It may be necessary to adjust the cable after fitting. See page 11 for details.

3. FITTING THE REEL CLUTCH LEVER.

Loosen the screws supplied, from the lever housing and attach the lever housing on the outside righthand side of the upper handle. Make sure the cable runs above the lower handle cross bar. Tighten the screws.

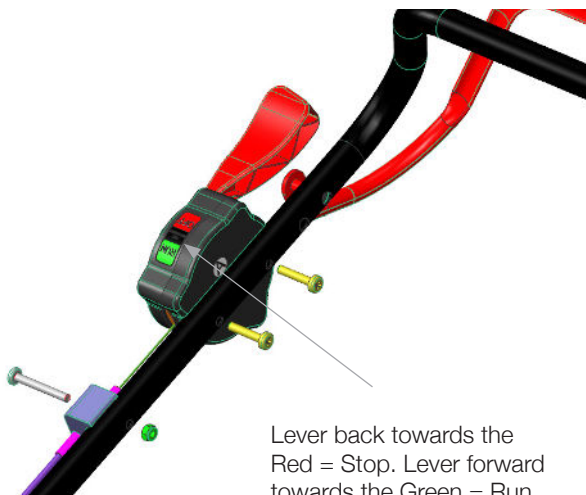

Lever back towards the Red = Stop. Lever forward towards the Green = Run.

4. FITTING THE CLUTCH LEVER CABLE.

The Reel clutch cable is attached to the lever housing. Use the nut & screw to attach it to the right-hand side of the handle. Make sure the cable runs above the lower handle cross bar. Tighten the screw & nut.

Before you start

Important!

The engine is shipped WITHOUT FUEL or OIL. After assembly, service the engine with fuel and oil as instructed in the separate engine manual packed with your machine. Running your mower with insufficient oil will damage the engine and invalidate your warranty

Be sure that...

- The operator reads and understands this manual,
- The daily maintenance checks have been properly carried out and the mower is in good working order.
- The operator wears safe clothing and eye protection. Failure to do so could result in damage and risk to health and safety

IDENTIFICATION OF CONTROLS

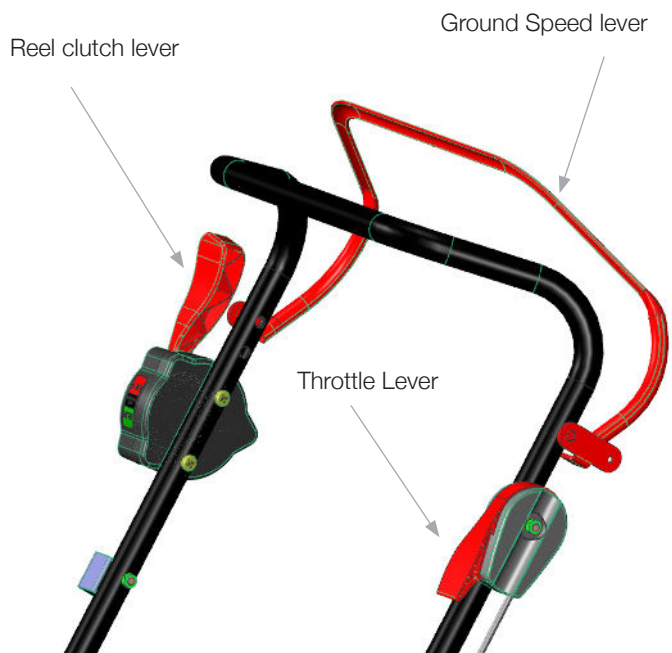

THROTTLE CONTROL LEVER

The throttle control lever is located to the left of upper handle. It controls the engine maximum speed which governs how fast the machine is propelled.

It is not necessary to operate the mower at full throttle. Often 50% - 75% throttle is sufficient.

Note!

The engine speed dictates the speed the mower is propelled

ROLLER CLUTCH LEVER

The reel lever is on the right of the upper handle. It engages the cutting reel. Move the lever to the forward position (GREEN) to engage, pull it back to (RED) position to disengage.

CUTTING REEL CLUTCH LEVER.

The reel lever is on the right of the upper handle. It engages the cutting reel. Move the lever to the forward position (GREEN) to engage, pull it back to (RED) position to disengage.

RECOIL PULL START HANDLE

Refer to the engine owner's handbook for details.

CLEAR THE AREA TO BE MOWN

Before commencing mowing, ensure the lawn is free from obstructions, such as stones, etc. Contact with objects of this type may damage the cutting reel and bedknife.

Using your reel mower

STARTING THE ENGINE

Ensure the reel clutch bail is in the disengaged position before starting the engine. Turn the ignition switch (if fitted) to the 'ON' position.

Starting Procedure

If the engine has not been running recently move the choke control to the 'ON' position. The choke is on the side of the engine by the carburettor, refer engine owner's manual.

Stand to the right of the mower, grasp the starter grip, pull slowly until a resistance is felt and then pull forcefully to prevent kick-back. Repeat until the engine starts. Do not pull the cord with a jerk or release it until fully rewound. When the engine starts and has warmed up for a short time, move the choke to the 'OFF' position and throttle control to the desired speed. Should the engine not start due to 'flooding', move the Choke control to 'OFF' and pull the starter six times to clear the flooding.

After allowing the engine to warm up, mowing may commence by setting the throttle lever, so the engine is running sufficiently fast. Engage the clutch lever, then engage the roller clutch by moving the roller clutch lever forward towards the handle. Adjust the throttle to achieve a comfortable walking pace and guide the machine in the desired direction.

To Stop the machine, release the ground speed lever, disengage the reel lever. Then reduce the engine speed.

To move the machine without mowing. With the engine running, leave the clutch lever off and engage the roller clutch lever and guide the machine in the desired direction.

HINTS FOR EASY STARTING.

1. Start a warm engine with the control in the SLOW position.
2. Keep the mower clean and the reel clear of debris.

HARD STARTING CHECK LIST

Look for these faults:-

FUEL.

1. Insufficient fuel in tank.
2. Stale fuel.
3. Water or dirt in fuel.
4. Blocked air vent in fuel tank cap.

IGNITION.

1. Loose spark plug wire.
2. Dirty spark plug electrodes.
3. Incorrect spark plug gap.
4. Incorrect spark plug type.

OTHER.

1. Choked air filter (Dirt or oil).
2. Engine throttle control cable incorrectly adjusted.
3. Lower cutting blade incorrectly adjusted.

MOWING FLAT OPEN AREAS

When mowing flat open areas it is best to first cut a margin approximately widths at each end where you wish to turn the mower and then mow at right angles to the margins with parallel cuts until the area is completed. This leaves your lawn with a very pleasing appearance. When turning at the end of each cut, disengage the clutch and press down on the handles, turning the mower on its rear roller. Once the throttle has been set to suit your pace, there is no need for further adjustment unless you should encounter very heavy grass growth. The mower can be controlled entirely by means of the Roller clutch bail.

GROUND SPEED LEVER

When making tight turns, release the Ground Speed Lever to its open position and re-engage the clutch when you want to resume cutting.

When mowing around verges, the cutting reel and rear roller should slightly overhang the bail edge ground speed lever.

MOWING SLOPING AREAS

Important!
Mowing on slopes requires extra care.

Generally speaking, your mower will mow lawns on which you can reasonably walk. When mowing a sloping area, mow across the slope wherever possible, with your machine pointing slightly uphill. This way you will find it will do a satisfactory job without sliding. If you find it necessary to mow up and down the slope and the rear roller shows a tendency to slip on the upward run, then press down on the handle to increase traction.

PAUSING BETWEEN MOWING

Whenever the mower is left with the engine running e.g. when emptying the catcher close the throttle to allow the engine to idle. Idling the engine automatically uncouples the drive to the cutting reel, reducing wear. If your mower is fitted with an OPC system, the engine will stop automatically when you release your grip on the OPC bail.

If the mower is to be left unattended for a longer period, it is advisable to stop the engine to prevent possible overheating.

If the mower is to be left unattended for a long period of time, disengage the reel lever back to the red stop position to stop the reel blades from spinning.

GRASS DEFLECTOR ADJUSTMENTS

When cutting grass at various lengths, it may be found that the cuttings tend to be thrown either too high or low in the catcher, in which case poor loading will result. To eliminate this the deflector should be adjusted. This can be done quite simply by slackening off the two bolts 'A' on the front edge of the main frame and moving the deflector in or out until the desired effect is obtained, then re-tighten the bolts. If set too far back, grass will be thrown too low in the catcher, or if too close to the cutting reel, grass will be thrown over the top of the catcher.

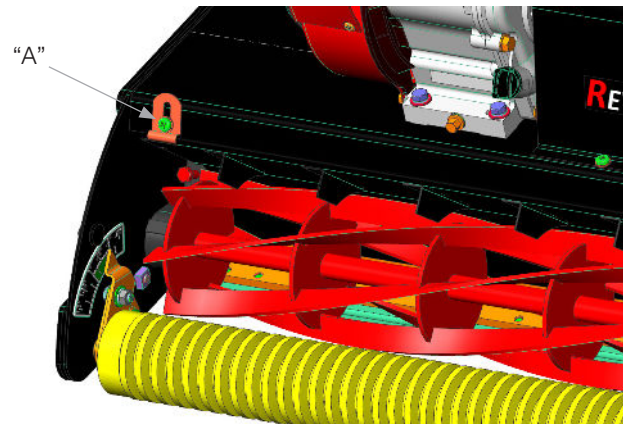

Adjustments for best performance

CUTTING HEIGHT ADJUSTMENT

The height of cut 'C' can be altered to suit grass and/or ground conditions by simple rotation of the height adjustment knob situated immediately forward of the chain cover, see photo pages 6 and 7.

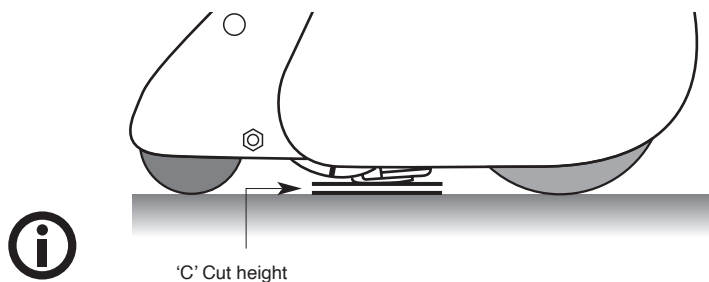

- The height of cut 'C' can be altered to suit grass and/or ground conditions by simply rotating the Height Adjustment Knob. (See image on pages 5)
- For a shorter cut turn the height adjustment knob counter-clockwise.
- For a longer cut turn the height adjustment knob clockwise.

Never set the cutting height so low that the bedknife touches the ground. For a healthy attractive lawn we do not recommend cutting at heights below 1/2"-1". Very long grass is best tackled with the rollers set to give the highest possible cut.

CUTTING REEL ADJUSTMENTS

To obtain clean cutting, it is necessary to maintain the setting of the cutting reel relative to the bedknife. When shipped, the setting is correct, but after a period of use, adjustment will be required.

It will normally be necessary to move the cutting reel closer to the bedknife to accommodate wear. To do this the adjusting screws 'B' on both sides of the machine should be turned clockwise making small alterations to each screw alternately until the cutting reel just makes contact with the bedknife blade. This can be determined by placing a sheet of index card between the reel and the blade. Rotate the reel by hand, and the paper should be cut. Once this adjustment has been established THE REEL SHOULD NOT TOUCH THE BEDKNIFE BUT STILL CUT THE PAPER. Provided the reel and bedknife are in good condition this setting will give clean cutting without undue reel-to-bedknife pressures.

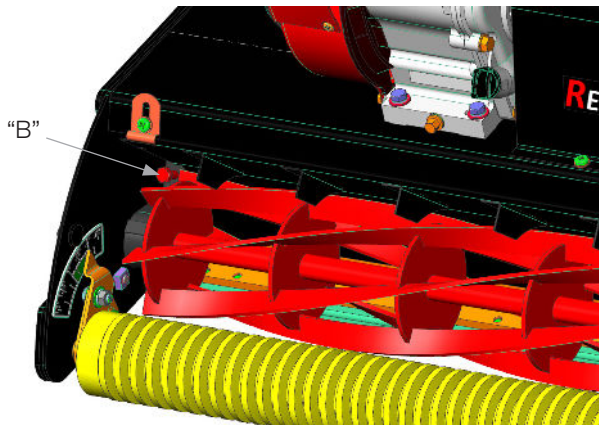

FRONT ROLLER ADJUSTMENTS

To obtain level, even mowing it is necessary to keep front rollers parallel to the rear roller. The setting was adjusted before shipping but after a period of use, adjustment may be required. Place the mower on a flat surface to check if the front roller is level. If it is not level the adjustment can be achieved by loosening the locknut and bolt 'A' and adjusting the roller bracket 'B' backward and forward, this will move that end of the roller up or down. When the front roller is level and parallel to the rear roller tighten the nut and bolt.



REAR ROLLER ADJUSTMENT

The weatherboarding is set during manufacture, but after a period of use, adjustment might be required.

Place the mower on a flat surface. On the right hand side of the mower, loosen the two bolts & nuts in the slotted holes 'A' enough to slide then loosen the bolt & nut in the rear hole 'B'. Swivel the bearing housing (inside) to raise or lower the right hand side of the rear roller and level out the bedknife. Lock the bolts & nuts.

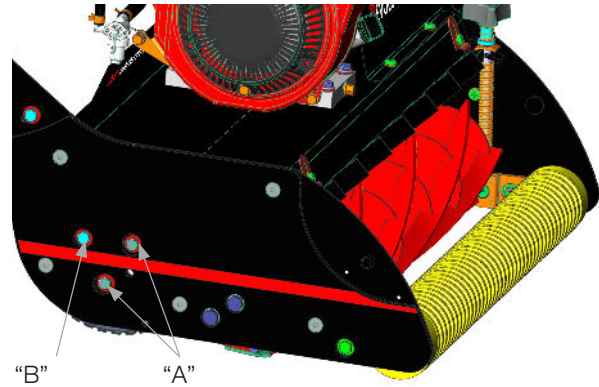

Important!

Harsh settings increase the load on the mower and accelerate the wear of the cutting reel.

TRANSMISSION ADJUSTMENT

Normal stretch and wear makes periodic chain adjustments necessary. When adjusted correctly all chains should be slightly slack in all directions. To check or adjust chains it is necessary to remove the chain cover by removing its retaining screws and freeing it from machine. Adjust as follows:

DRIVE CHAINS-PRIMARY, SECONDARY AND FINAL

The final chain is not adjustable. The primary and secondary chains normally require adjustment only when the cutting unit is reground. If, however, adjustment is required before this, it is recommended you contact your Dealer. If at any time a chain is removed, take care when replacing the connecting link that the gap in the spring clip points away from the direction of rotation.

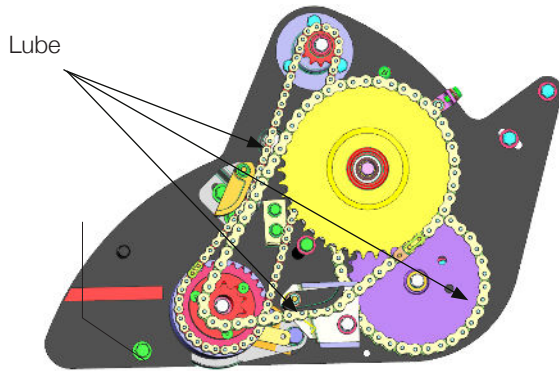

The two nuts on the lower end of the clutch cable sleeve are not intended for adjustment of the cable length.

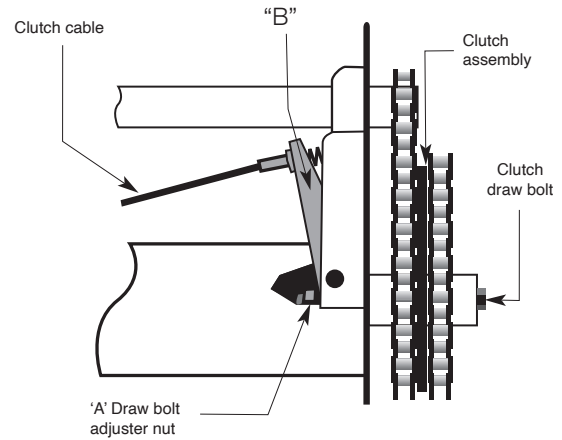

REAR ROLLER CLUTCH ADJUSTMENTS

After a period of use, adjustment will be required to compensate for cable stretch etc.

There are two adjusting points.

1. The cable anchor at the top of the handle.
2. The draw bolt through the centre of the clutch.

ADJUSTING THE ROLLER CLUTCH CABLE

Do not adjust the draw bolt unless the upper cable anchor has reached the end of its travel. To adjust the cable anchor rotate the thumb wheel counterclockwise (viewed from behind the handle) to increase the clutch pressure.

ADJUSTING THE ROLLER CLUTCH DRAW BOLT

If the draw bolt requires adjustment remove the chain and shaft covers.

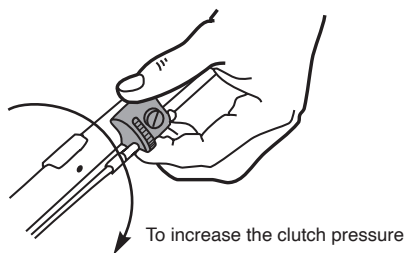

Adjust the nut 'A' on the inner end of the draw bolt until the clutch operating lever 'B' is parallel to the mower side plate when the clutch drive is just engaging. It should not be necessary to adjust the ferrule at the lower end of the clutch cable.

Cutting Reel Clutch Adjustment

After a period of use, adjustment will be required to compensate for cable stretch. To adjust the clutch cable, rotate the thumb wheel counterclockwise (viewed from behind the handle) to increase the clutch pressure.

General Maintenance

SERVICING THE ENGINE

See separate engine Owner's Manual.

INSPECTING AND LUBRICATING THE MOWER

The reel bearings are sealed for life and do not require lubrication.

The following lubrication points should be oiled approximately every 25 hours of operation with SAE30-40 oil.

1. Driving Chains. Keep moistened with all purpose chain lubricant. This lubrication requires the removal of the chain cover, which can be lifted clear after unscrewing the three retaining screws.
2. Ground speed lever pivot points.
3. Height Adjustment screw thread. Hand adjustment knob all pivot points.
4. Cables. Apply oil to each end.
5. Self Adjusting Chain Adjuster. Apply oil to pivot.



Warning!

NEVER LUBRICATE WHILE MOTOR IS RUNNING.

Cleaning and storage

There is a direct relationship between the mower's life and the care and attention given to the mower both during and after operation. It is important that the mower is thoroughly cleaned after use and inspected so that it will be in good working order the next time it is required.

Thoroughly clean the engine, under the chassis, the rollers and the grass catcher. Use of a high pressure water jet, especially around the engine, may force water into places where it may drive out lubricants or cause hard starting from ignition damage.

LONG TERM STORAGE:

After each mowing season or if the mower is not going to be used for 30 days or more, it is recommended that the fuel shut off valve be closed off (where fitted) and the fuel tank be drained as modern fuels have a short shelf life. The mower should then be started up and run until all of the fuel left in the system is used. While the engine is warm, drain the engine oil and refill with the correct grade to the required level. Remove the spark plug and pour 5ml of engine oil into the engine cylinder, crank slowly to distribute the oil and replace the spark plug. Store the mower in a clean dry area away from direct sunlight.

Adjust the cutting reel away from the bedknife and apply a thin layer of grease to the cutting edges to prevent corrosion through the storage period. If possible, spray the mower with a thin film of light oil to protect it.

Always store the mower on a flat, level surface.

Specifications

Model	REV26-6
Weight	181 Lbs
Cut Width	26"

ENGINE INFORMATION

FOR DETAILED SPECIFICATIONS REFER SEPARATE ENGINE OWNER'S MANUAL.

Troubleshooting

Fault	Possible Cause	Remedy
Some uncut or poorly cut strands of grass.	Cutting reel is partially out of contact with the bedknife.	Re-adjust cutting reel to bedknife.
	Cutting reel is in heavy contact with bedknife.	Re-adjust cutting reel to bedknife.
	Height of cut is too high.	Lower height of cut setting.
	Cutting edges of cutting reel/bedknife are rounded.	Regrind cutting edges.
Scalping.	Undulations too severe for height of cut setting.	Raise height of cut.
Excessive bedknife wear.	Bedknife in heavy ground contact.	Raise height of cut.
	Cutting edges of cutting reel/bedknife are rounded.	Regrind cutting edges.
	Cutting reel is in heavy contact with the bedknife.	Re-adjust cutting reel to bedknife.
	Damaged cutting reel or bedknife.	Regrind or replace as necessary.
Engine does not start, runs erratically.	Choke incorrectly set.	Move choke lever.
	Fuel tank empty or fuel shut off valve closed.	Fill tank with recommended fuel grade and open fuel shut-off valve.
	Faulty recoil starter.	Return unit to dealer.
	Engine Air Filter is dirty.	Service or replace Engine Air Filter.
	Spark plug loose.	Tighten spark plug.
	Spark plug cable disconnected.	Refit cable to spark plug.
	Defective spark plug.	Replace damaged spark plug.
	Spark plug gap incorrect.	Replace damaged spark plug
	Carburettor is flooded with fuel.	Move throttle to 'Stop', position pull the starter cord 5-6 times, move throttle to 'Run' and start engine.
	Not enough oil (oil safety switch)	Check oil level, fill with new oil.
Engine misfires at high speed.	Dirt water or stale fuel in the tank.	Drain and clean fuel tank. Refill with clean fresh fuel before starting.
	Vent hole in the filler cap is blocked.	Clean or replace fuel cap.
	Spark plug gap too small.	Refer to Engine Manual.
Engine idles poorly.	Engine Air Filter is dirty.	Service or replace Engine Air Filter
Cutting cylinder does not turn.	Cable stretched.	Adjust the thumb wheel as mentioned in this manual.
	Broken Cable.	Replace Cable.
	Clutch bolt is loose	Add lock tight and tighten or contact Reel Rollers Support Representative.
Cutting cylinder does not stop.	Cable too tight.	Adjust the thumb wheel as mentioned in this manual.
	Internal spring broken.	Contact Reel Rollers Support Representative.

Troubleshooting (continued)

Fault	Possible Cause	Remedy
Engine overheats.	Blocked engine cooling fins and air passages.	Remove debris from around engine.
	Cooling air flow restricted.	Remove debris from around engine.
	Incorrect spark plug fitted.	Refer to Engine Manual.
	Low engine oil level.	Check oil level and top up if needed.
Cutting reel clutch is stuck.	Misalignment of clutch	Contact Reel Rollers Support Representative.
Engine vibrates and/or is noisy	Worn or damaged bearing(s).	Remove and inspect suspect bearings, replace if necessary.
	Worn or damaged drive chains and/or sprockets.	Remove and inspect suspect chains and sprocket, replace if necessary.
Oil Leaks from muffler or air filter	Engine oil sump over filled.	Check oil level and drain excess oil.
	Mower tipped back on handle bar	Check oil level, air cleaner and spark plug and correct as necessary.

Should faults persist, consult your Reel Rollers Support Team.



Parts & Support



Reel Rollers Super Store
2333 Peachtree industrial Blvd.
Buford, GA 30518
www.reelrollers.com